



# TOWNSHIP OF DEPTFORD

Gloucester County, New Jersey

Municipal Building  
1011 Cooper Street  
Deptford, New Jersey 08096  
(856) 845-5300 phone  
(856) 845-8995 fax  
[www.deptford-nj.org](http://www.deptford-nj.org)

Construction Office

## POOL HANDOUT

### THIS INFORMATION IS FOR GUIDANCE ONLY

#### REQUIREMENTS

- Zoning approval (please allow 5-10 working days for zoning approval).
- A signed, completed **Construction Permit Application Jacket** signed by whoever is installing pool. (If you are purchasing the pool from a pool company and they are installing it for you, they must complete the application where appropriate and provide a copy of their Home Improvement Contractors License)
- A signed, completed **Building Subcode Technical Section**
- A signed, completed **Electrical Subcode Technical Section** (Homeowner may do the electrical work only if the property is their primary residence. If NJ Licensed Electrician is doing the work the Technical Section must be signed and sealed by the Electrician).
- If required a signed, completed **Plumbing Subcode Technical Section** (for Pool heater and drain) (Homeowner may do the plumbing work only if the property is their primary residence. If NJ Licensed Plumbing Contractor is doing the work the Technical Section must be signed and sealed by the Plumbing Contractor).
- If required a signed, completed **Fire Subcode Technical Section** (for Pool heater)
- Plans Required:
  - ✓ **ABOVE GROUND POOLS:**
    - Plans consist of Pool, Pump and Filter Brochures
    - **2 sets** of Electrical Diagrams to include bonding signed and sealed by NJ licensed Electrician (if work performed by Electrician) or prepared and signed by homeowner (if primary residence only).
    - **For pools with decks** include deck plan or Brochure
    - **For pools with Ladder Enclosures** include Ladder Enclosure Brochure
    - **For pools with Heaters** include Heater Brochure and 2 gas piping diagrams
  - ✓ **INGROUND POOLS:**
    - **2 sets** of Plans signed and sealed by a NJ licensed Architect or Engineer
    - **2 sets** of Electrical Diagrams to include equipment potential/grid bonding signed and sealed by NJ licensed Electrician (if work performed by Electrician) or prepared and signed by homeowner (if primary residence only).
    - **For pools with Heaters** include Heater Brochure and 2 gas piping diagrams

- Once completed applications and plans are submitted to the Construction Office, please allow **20 business days** for the permit to be reviewed, the Construction Office will call whoever is listed as **“Principal Contractor”** when permit is ready to be paid for and issued. Permit fees will be calculated during the review process.

### **REQUIRED INSPECTIONS**

Please call **856-686-2223** or **856-686-2225** a minimum of 24 hours in advance to schedule inspections. **Building and Plumbing Inspections** are scheduled **Monday thru Friday 8:30 am to 3 pm**, **Electrical Inspections** are scheduled **Monday thru Friday 3 pm to 7 pm**. Times are **not given**, therefore please allow enough time for the inspector to conduct the inspection.

✓ **ABOVE GROUND POOLS:**

- **Building:** Final Inspection (1 inspection) See Barrier Requirements attached.
- **Electrical:** Trench/Bonding Inspection & Final Inspection (2 inspections)
- **Plumbing (if pool heater installed):** Gas piping Inspection & Final Inspection (2 inspections) (for pools with heaters, a vapor resistant cover must be on site for final inspection)
- **Fire (if pool heater installed):** Final Inspection

✓ **IN-GROUND POOLS:**

- **Building:** Footing Inspection & Final Inspection (2 inspections) See Barrier Requirements attached.
- **Electrical:** Trench/Bonding Inspection & Final Inspection (2 inspections)
- **Plumbing:** Rough Bottom Drain Inspection & Final Inspection (2 inspections)
- **Plumbing (if pool heater installed):** Gas piping Inspection (1 additional inspection) (for pools with heaters, a vapor resistant cover must be on site for final inspection)
- **Fire (if pool heater installed):** Final Inspection

**Please note: You must schedule and pass ALL final inspections prior to pool usage.**

### **INTERNATIONAL SWIMMING POOL AND SPA CODE (ISPSC) 2015**

## SECTION 701 GENERAL

**701.1 Scope.** This chapter describes certain criteria for the design, manufacturing, and testing of *onground storable pools* intended for *residential* use. This includes portable pools with flexible or nonrigid side walls that achieve their structural integrity by means of uniform shape, support frame or a combination thereof, and that can be disassembled for storage or relocation. This chapter includes what has been commonly referred to in past standards or codes as onground or above-ground pools.

**701.1.1 Permanent inground residential swimming pool.** This chapter does not apply to permanent inground *residential* pools, as defined in Chapter 8.

**701.2 General.** In addition to the requirements of this chapter, onground storable *residential swimming pools* shall also comply with the requirements of Chapter 3.

**701.3 Floor slopes.** Floor slopes shall be uniform and in accordance with Sections 701.3.1 through 701.3.4.

**701.3.1 Shallow end.** The slope of the floor from the shallow end wall towards the deep area shall not exceed 1 unit vertical in 7 units horizontal (14-percent slope) to the point of the first slope change.

**701.3.2 Transition.** The slope of the floor from the point of the first slope change towards the deepest point shall not exceed 1 unit vertical in 3 units horizontal (33-percent slope).

**701.3.3 Adjacent.** The slope adjacent to the *shallow area* shall not exceed 1 unit vertical in 3 units horizontal (33-percent slope) and the slope adjacent to the side walls shall not exceed 1 unit vertical in 1 unit horizontal (100-percent slope).

**701.3.4 Change point.** The point of the first slope change shall be defined as the point at which the *shallow area* slope exceeds 1 unit vertical in 7 units horizontal (14-percent slope) and is not less than 6 feet (1889 mm) from the shallow end wall of the pool.

**701.4 Identification.** For onground storable *residential* pools with a vinyl liner, the manufacturer's name and the liner identification number shall be affixed to the liner. For onground storable *residential* pools without a liner, the manufacturer's name and the liner identification number shall be affixed to the exterior of the pool structure.

**701.5 Installation.** *Onground storable pools* shall be installed in accordance with the manufacturer's instructions.

## SECTION 702 LADDERS AND STAIRS

**702.1 Ladders and stairs.** Pools shall have a means of entry and exit consisting of not less than one *ladder* or a *ladder* and staircase combination.

**702.2 Type A and Type B ladders.** *Type A, double access,* and *Type B, limited access,* A-frame ladders shall comply with Sections 702.2.1 through 702.2.7. See Figure 702.2.

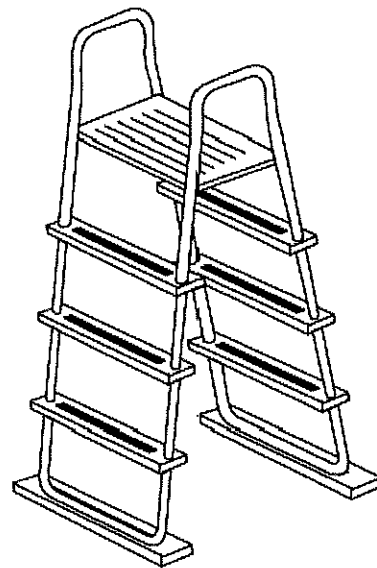

**FIGURE 702.2 TYPICAL A-FRAME LADDER TYPES A AND B**

**702.2.1 Barrier required.** Ladders in the pool shall have a physical barrier to prevent children from swimming through the riser openings or behind the *ladder*.

**Exception:** Barriers for ladders shall not be required where the ladder manufacturer provides a certification statement that the ladder complies with the ladder entrapment test requirements of APSP 4.

**702.2.2 Platform.** Where an A-frame ladder has a platform between the *handrails*, the platform shall have a width of not less than 12 inches (305 mm) and a length of not less than 12 inches (305 mm). The platform shall be at or above the highest ladder tread. The walking surface of the platform shall be *slip resistant*.

**702.2.3 Handrails or handholds.** A-frame ladders shall have two *handrails* or handholds that serve all treads. The height of the handrails or handholds shall be not less than 20 inches (508 mm) above the platform or uppermost tread, whichever is higher.

**702.2.4 Diameter.** The outside diameter of *handrails* or handholds shall be not less than 1 inch (25 mm) and not greater than 1.9 inches (48 mm).

**702.2.5 Clear distance.** The clear distance between *ladder handrails* shall not be less than a space of 12 inches (305 mm).

**702.2.6 Treads.** *Ladder* treads shall have a horizontal uniform depth of not less than 2 inches (51 mm).

**702.2.7 Riser height.** Risers, other than the bottom riser shall be of a uniform height of not less than 7 inches (178 mm) and not greater than 12 inches (305 mm). The bottom riser height shall be not less than 7 inches (178 mm) and not greater than 12 inches (305 mm). The vertical distance from the platform or top of the pool structure to the uppermost tread shall be the same as the uniform riser heights.

**702.3 Type C staircase ladders (ground to deck).** *Type C staircase ladders* shall comply with Sections 702.3.1 through 702.3.6. See Figure 702.3.

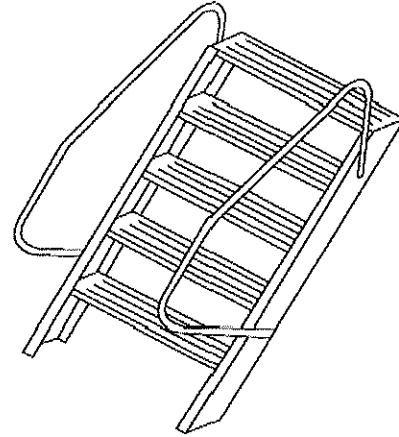

**FIGURE 702.3 TYPICAL STAIRCASE LADDER TYPE C**

**702.3.1 Handrails or handholds.** Staircase ladders shall have not less than two handrails or handholds that serve all treads. The height of the handrails or handholds shall be not less than 20 inches (508 mm) above the platform or uppermost tread, whichever is higher.

**702.3.2 Diameter.** The outside diameter of *handrails* and handholds shall be not less than 1 inch (25 mm) and not greater than 1.9 inches (48 mm).

**702.3.3 Treads.** *Ladder* treads shall have a horizontal uniform depth of not less than 4 inches (102 mm).

**702.3.4 Riser height.** Risers, other than the bottom riser shall be of a uniform height of not less than 7 inches (178 mm) and not greater than 12 inches (305 mm). The bottom riser height shall be not less than 7 inches (178 mm) and not greater than 12 inches (305 mm). The vertical distance from the platform or top of the pool structure to the uppermost tread shall be the same as the uniform riser heights.

**702.3.5 Top step.** The top step of a staircase *ladder* shall be flush with the deck or between 7 inches (178 mm) to 12 inches (305 mm) below the deck level.

**702.3.6 Width.** Steps shall have a minimum unobstructed width of 19 inches (483 mm) between the side rails.

**702.4 Type D in-pool ladders.** Type *D in-pool ladders* shall be in accordance with Sections 702.4.1 through 702.4.7. See Figure 702.4.

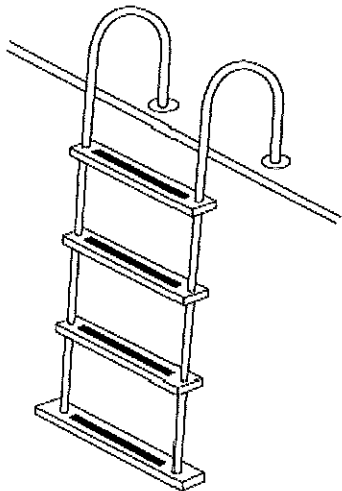

**FIGURE 702.4 TYPICAL IN-POOL LADDER TYPE D**

**702.4.1 Clearance.** There shall be a clearance of not less than 3 inches (76 mm) and not greater than 6 inches (152 mm) between the pool wall and the *ladder*.

**702.4.2 Handrails or handholds.** *Ladders* shall be equipped with two *handrails* or handholds that extend above the platform or deck not less than 20 inches (508 mm).

**702.4.3 Clear distance.** The clear distance between *ladder handrails* shall not be less than 12 inches (305 mm).

**702.4.4 Diameter.** The outside diameter of *handrails* and handholds shall be not less than 1 inch (25 mm) and not greater than 1.9 inches (48 mm).

**702.4.5 Riser height.** Risers, other than the bottom riser shall be of a uniform height of not less than 7 inches (178 mm) and not greater than 12 inches (305 mm). The bottom riser height shall be not less than 7 inches (178 mm) and not greater than 12 inches (305 mm).

**702.4.6 Top tread.** The vertical distance from the pool coping, deck, or step surface to the uppermost tread shall be not less than 7 inches

(178 mm) and not greater than 12 inches (305 mm) and uniform with other riser heights.

**702.4.7 Tread depth.** *Ladder* treads shall have a horizontal uniform depth of not less than 2 inches (51 mm).

**702.5 Type E protruding in-pool stairs.** Type *E* protruding in-pool stairs shall be in accordance with Sections 702.5.1 through 702.5.7. See Figure 702.5.

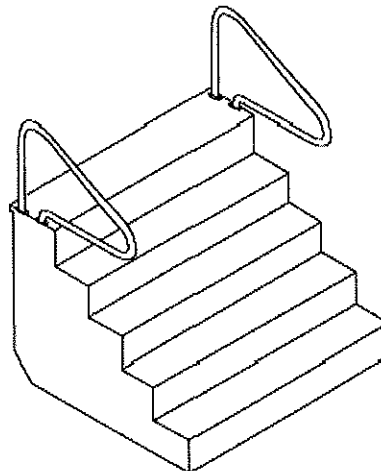

**FIGURE 702.5 TYPICAL IN-POOL STAIRCASE TYPES E and F**

**702.5.1 Barrier required.** In-pool stairs shall have a physical barrier to prevent children from swimming through the riser openings or behind the in-pool ladder.

**702.5.2 Handrails or handholds.** In-pool stairs shall be equipped with not less than one *handrail* or handhold that serves all treads with a height of not less than 20 inches (508 mm) above the platform or uppermost tread, whichever is higher.

**702.5.3 Removable handrails.** Where *handrails* are removable, they shall be installed such that they cannot be removed without the use of tools.

**702.5.4 Leading edge distance.** The leading edge of *handrails* shall be 18 inches (457 mm)  $\pm$  3 inches ( $\pm$  76 mm), horizontally from the vertical plane of the bottom riser.

**702.5.5 Diameter.** The outside diameter of *handrails* or handholds shall be not less than 1 inch (25 mm) and not greater than 1.9 inches (48 mm).

**702.5.6 Tread width and depth.** Treads shall have an unobstructed horizontal depth of not less than 10 inches (254 mm) and an unobstructed surface area of not less than 240 square inches (.015 m<sup>2</sup>).

**702.5.7 Uniform riser height.** Risers, other than the bottom riser, shall be of uniform height that is not less than 7 inches (178 mm) and not greater than 12 inches (305 mm). The bottom riser height shall be not less than 7 inches (178 mm) and not greater than 12 inches (305 mm). The vertical distance from the pool coping, deck or step surface to the uppermost tread of the stairs shall be the same as the uniform riser heights.

**702.6 Type F recessed in-pool stairs.** *Type F* recessed in-pool stairs shall be in accordance with Sections 702.6.1 through 702.6.7. See Figure 702.5.

**702.6.1 Barrier required.** In-pool stairs shall have a physical barrier to prevent children from swimming through the riser openings or behind the in-pool stairs.

**702.6.2 Handrail or handhold.** In-pool stairs shall be equipped with not less than one *handrail* or handhold that serves all treads with a height of not less than 20 inches (508 mm) above the platform or uppermost tread, whichever is higher.

**702.6.3 Removable handrails.** Where *handrails* are removable, they shall be installed such that they cannot be removed without the use of tools.

**702.6.4 Leading edge distance.** The leading edge of *handrails* shall be 18 inches (457 mm) ± 3 inches (± 76 mm), horizontally from the vertical plane of the bottom riser.

**702.6.5 Diameter.** The outside diameter of *handrails* and handholds shall be not less than 1 inch (25 mm) and not greater than 1.9 inches (48 mm).

**702.6.6 Tread width and depth.** Treads shall have an unobstructed horizontal depth of not less than 10 inches (254 mm) at all points and an

unobstructed surface area of not less than 240 square inches (0.15 m<sup>2</sup>).

**702.6.7 Uniform riser height.** Risers, other than the bottom riser, shall be of uniform height that is not less than 7 inches (178 mm) and not greater than 12 inches (305 mm). The bottom riser height shall be not less than 7 inches (178 mm) and not greater than 12 inches (305 mm). The vertical distance from the pool coping, deck or step surface to the uppermost tread of the stairs shall be the same as the uniform riser heights.

## SECTION 703 DECKS

**703.1 General.** Decks provided by the pool manufacturer shall be installed accordance with the manufacturer's instructions. Decks fabricated on-site shall be in accordance with the *International Residential Code*.

**703.2 Cantilevered.** The top surface of a cantilevered deck shall be not greater than 1 inch (25mm) higher than the top of the pool wall. See Figure 703.4. The top surface of a noncantilevered deck shall be not higher than the top of the pool wall.

**703.3 No gaps.** Decks that are installed flush with the top rail of the pool shall have all gap openings between the deck and top rails closed-off or capped.

**703.4 Extension over pool.** Where a deck extends inside the top rail of the pool, it shall extend not more than 3 inches (76 mm) beyond the inside of the top rail of the pool in accordance with Figure 703.4 and shall have a smooth finish.

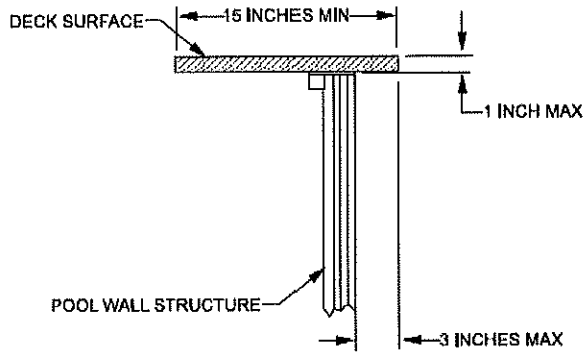

For SI: 1 inch = 25.4 mm.

**FIGURE 703.4 TYPICAL CANTILEVER DECK SUPPORT**

**703.5 Slip resistant.** The deck walking surface shall be *slip resistant*.

**703.6 Walk-around decks.** Walk-around decks shall have a level walking surface of not less than 15 inches (381 mm) in width, as measured from the inside edge of the pool top rail to the outside of the pool walk-around. See Figure 703.6.

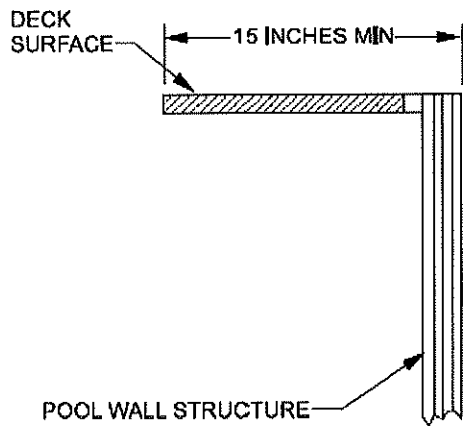

For SI: 1 inch = 25.4 mm.

**FIGURE 703.6 WALK-AROUND DECK WIDTH**

## SECTION 704 CIRCULATION SYSTEM

**704.1 General.** A circulation system consisting of pumps, hoses, tubing, piping, return inlets, suction outlets, filters and other related equipment that provides for the circulation of water throughout the pool shall be located so that such items cannot be used by young children as a means of access to the pool.

**704.2 Installation and support.** Circulation equipment shall be installed, mounted and supported in accordance with the manufacturer's instructions.

**704.3 Draining the system.** In climates subject to freezing, *circulation system* equipment shall be designed and fabricated to drain the pool water from the equipment and exposed piping, by removal of drain plugs and manipulating valves or by other methods in accordance with the manufacturer's instructions.

**704.4 Turnover.** A pump including a motor shall be provided for circulation of the pool water. The equipment shall be sized to provide a turnover of the pool water not less than once every 12 hours. The system shall be designed to provide the required *turnover rate* based on the manufacturer's specified maximum flow rate of the filter, with a clean media condition of the filter. The system flow shall not exceed the filter manufacturer's maximum filter flow rate.

**704.5 Piping and fittings.** The process piping of the circulation system, including but not limited to hoses, tubing, piping, and fittings, shall be made of nontoxic materials and shall be capable of withstanding an internal pressure of not less than 1 ½ times the rated pressure of the pump. Piping on the suction side of the pump shall not collapse when flow into such pipe is blocked.

**SECTION 305**  
**BARRIER REQUIREMENTS**

**305.1 General.** The provisions of this section shall apply to the design of *barriers* for *aquatic vessels*. These design controls are intended to provide protection against the potential drowning and near drowning by restricting access to such vessels. These requirements provide an integrated level of protection against potential drowning through the use of physical barriers and warning devices.

**Exceptions:**

1. *Spas* and hot tubs with a lockable safety cover that complies with ASTM F 1346.
2. ~~Swimming pools with a powered safety cover that complies with ASTM 1346.~~

**305.2 Outdoor swimming pools and spas.** All outdoor *aquatic vessels* and indoor swimming pools shall be surrounded by a *barrier* that complies with Sections 305.2.1 through 305.7.

**305.2.1 Barrier height and clearances.** Barrier heights and clearances shall be in accordance with all of the following:

1. The top of the *barrier* shall be not less than 48 inches (1219 mm) above grade where measured on the side of the *barrier* that faces away from the *aquatic vessel*. Such height shall exist around the entire perimeter of the vessel and for a distance of 3 feet (914 mm) where measured horizontally from the required *barrier*.
2. The vertical clearance between grade and the bottom of the *barrier* shall not exceed 2 inches (51 mm) for grade surfaces that are not solid, such as grass or gravel, where measured on the side of the barrier that faces away from the vessel.
3. The vertical clearance between a surface below the barrier to a solid surface, such as concrete, and the bottom of the required *barrier* shall not exceed 4 inches (102 mm) where measured on the side of the required barrier that faces

away from the vessel.

4. Where the top of the vessel structure is above grade, the *barrier* shall be installed on grade or shall be mounted on top of the vessel, the vertical clearance between the top of the vessel and the bottom of the barrier shall not exceed 4 inches (102 mm).

**305.2.2 Openings.** Openings in the *barrier* shall not allow passage of a 4 inch (102 mm) diameter sphere.

**305.2.3 Solid barrier surfaces.** Solid *barriers* that do not have openings shall not contain indentations or protrusions that form handholds and footholds, except for normal construction tolerances and tooled masonry joints.

**305.2.4 Mesh restraining barrier/fence.** Mesh fences, other than chain link fences in accordance with Section 305.2.7, shall be installed in accordance with the manufacturer's instructions and shall comply with the following:

1. The bottom of the mesh restraining fence shall be not more than 1 inch (25 mm) above the deck or installed surface or grade.
2. The maximum vertical clearance from the bottom of the mesh fence and the solid surface shall not permit the fence to be lifted more than 4 inches (102 mm) from grade or decking.
3. The fence shall be designed and constructed so that it does not allow passage of a 4-inch (102 mm) sphere under any mesh panel. The maximum vertical clearance from the bottom of the mesh fence and the solid surface shall not be more than 4 inches (102 mm) from grade or decking.
4. An attachment device shall attach each barrier section at a height not lower than 45 inches (1143 mm) above grade. Common attachment devices include, but are not limited to , devices that provide the security equal to or greater than that of a hook-and-eye-type latch incorporating a spring-actuated retaining



- lever such as a safety gate hook.
5. Where a hinged gate is used with a mesh *barrier*, the gate shall comply with Section 305.3.
  6. Patio deck sleeves such as vertical post receptacles which are placed inside the patio surface shall be of a nonconductive material.
  7. Mesh fences shall not be used on top of on ground *residential pools*.

**305.2.5 Closely spaced horizontal members.** Where the *barrier* is composed of horizontal and vertical members and the distance between the tops of the horizontal members is less than 45 inches (1143 mm), the horizontal members shall be located on the *aquatic vessel* side of the fence. Spacing between vertical members shall not exceed 1.75 inches (44 mm) in width. Where there are decorative cutouts within vertical members, spacing within the cutouts shall not exceed 1.75 inches (44 mm) in width.

**305.2.6 Widely spaced horizontal members.** Where the *barrier* is composed of horizontal and vertical members and the distance between the tops of the horizontal members is 45 inches (1143 mm) or more, spacing between vertical members shall not exceed 4 inches (102 mm). Where there are decorative cutouts within vertical members, spacing within the cutouts shall not exceed 1.75 inches (44 mm) in width.

**305.2.7 Chain link dimensions.** The maximum opening formed by a chain link fence shall be not more than 1.75 inches (44 mm). Where the fence is provided with slats fastened at the top and bottom which reduces the openings, such openings shall be not more than 1.75 inches (44 mm).

**305.2.8 Diagonal members.** Where the *barrier* is composed of diagonal members, the maximum opening formed by the diagonal members shall be not more than 1.75 inches (44 mm). The angle of diagonal members shall not be greater than 45 degrees (0.79 rad) from vertical.

**305.2.9 Clear zone.** There shall be a clear zone of not less than 36 inches (914 mm) around the exterior of the *barrier* and around any permanent structures or equipment such as pumps, *filters* and heaters that can be used to climb the barrier.

**305.2.10 Poolside barrier setbacks.** The *aquatic vessel* side of the required *barrier* shall be not less than 20 inches (508 mm) from the water's edge.

**305.3 Gates.** Access gates shall comply with the requirements of Sections 305.3.1 through 305.3.3 and shall be equipped to accommodate a locking device. Pedestrian access gates shall open outward away from the vessel and shall be self-closing and have a self-latching device.

**305.3.1 Utility or service gates.** Gates not intended for pedestrian use, such as utility or service gates, shall remain locked when not in use.

**305.3.2 Double or multiple gates.** Double gates or multiple gates shall have at least one leaf secured in place and the adjacent leaf shall be secured with a self-latching device. The gate and *barrier* shall not have openings larger than  $\frac{1}{2}$  inch (12.7 mm) within 18 inches (457 mm) of the latch release mechanism. The self-latching device shall comply with the requirements of Section 305.3.3.

**305.3.3 Latches.** Where the release mechanism of the self-latching device is located less than 54 inches (1372 mm) from grade, the release mechanism shall be located on the vessel side of the gate at least 3 inches (76 mm) below the top of the gate, and the gate and *barrier* shall not have openings greater than  $\frac{1}{2}$  inch (12.7 mm) within 18 inches (457 mm) of the release mechanism.

**305.4 Structure wall as a barrier.** Where a wall of a dwelling or structure serves as part of a barrier, doors and operable windows with a sill height of less than 48 inches (1219 mm) that provide direct access to the aquatic vessel through the wall, shall be equipped with one or more of the following:

1. An alarm that produces an audible warning when the door or its screen or window is opened. The alarm shall be listed and labeled as a water hazard entrance alarm in accordance with UL 2017. In dwellings or structures not required to be Accessible units, Type A units or Type B units, the deactivation switch shall be located 54 inches (1372 mm) or more above the threshold of the door. In dwellings or structures required to be Accessible units, Type A units or Type B units, the deactivation switch shall be located not greater than 54 inches (1372 mm) and not less than 48 inches (1219 mm) above the threshold of the door.
2. A safety cover that is listed and labeled in accordance with ASTM F 1346.
3. An approved means of protection such as self-closing doors or self-latching devices, provided that the degree of protection afforded is not less than the protection afforded by Item 2.

**305.5 Pool structure as a barrier.** Where an onground residential pool structure is used as a barrier or where the barrier is mounted on top of the pool structure, the following shall apply:

1. An onground pool wall, itself, shall be permitted to be the barrier where the pool structure is on grade and the wall is at least 48 inches (1219 mm) above grade for the entire perimeter of the pool and complies

- with the requirements of Section 305.2.
2. Where the means of access is a ladder or steps, the ladder or steps shall be capable of being secured, locked or removed to prevent access or the ladder or steps shall be surrounded by a barrier that meets the requirements of this section.
3. When the ladder or steps are secured, locked or removed, any opening created shall not exceed 4 inches (102 mm) diameter sphere.
4. The barrier shall be installed in accordance with the manufacturer's instructions.

**305.6 Natural barriers.** In the case where the vessel area abuts the edge of a lake or other natural body of water, public access is not permitted or allowed along the shoreline, and required barriers extend to and beyond the water's edge a minimum of 18 inches (457 mm), a barrier is not required between the natural body of water shoreline and the vessel.

**305.7 Natural topography.** Natural topography that prevents direct access to the aquatic vessel area shall include but not be limited to mountains and natural rock formations. A natural barrier approved by the governing body shall be acceptable provided that the degree of protection is not less than the protection afforded by the requirements of Sections 305.2 through 305.5.

**IN-GROUND POOLS**  
**THIS FORM MUST BE SUBMITTED WITH CONSTRUCTION**  
**APPLICATION**

Property Owner: \_\_\_\_\_ Block: \_\_\_\_\_ Lot: \_\_\_\_\_

Project Address: \_\_\_\_\_

(if different from above)

Mailing Address: \_\_\_\_\_

\_\_\_\_\_

Pool Company: \_\_\_\_\_

Representative: \_\_\_\_\_ Phone: \_\_\_\_\_

**The in-ground pool being constructed at the above project address:**

\_\_\_\_\_ **WILL NOT** have submerged suction inlets (Bottom Drains) of any kind.

\_\_\_\_\_ **WILL HAVE** submerged suction inlets (Bottom Drains) and enclosed is a plumbing application & Brochure as required.

Signature of Representative: \_\_\_\_\_

Print Name Above Clearly: \_\_\_\_\_



# TOWNSHIP OF DEPTFORD

OFFICE OF THE CONSTRUCTION OFFICIAL  
2017 NEC ABOVE GROUND POOL HANDOUT

Required #8 solid copper equipotential bond conductor must follow the entire contour of the pool. Only listed splices shall be permitted. The conductor shall be 18"-20" from the walls of the pool. The conductor shall be 4"-6" below grade. The bond shall be connected to the pool frame in four areas. When the frame of the pool is of non conductive material the walls of the pool must be bonded where the two seam of the walls are bolted together. The pump motor shall also bond to the pool frame with a #8 wire. Art 680.26.

**NOTE**  
All conductors shall be copper. All outdoor receptacles covers shall be in-use (bubble cover) weatherproof type. #12 NM cable(romex) is a permitted wiring method inside of the dwelling only. All underground terminations (bugs and lugs) must be rated for direct burial. All hardware such as bolts, screws, nuts and washers must be stainless steel.

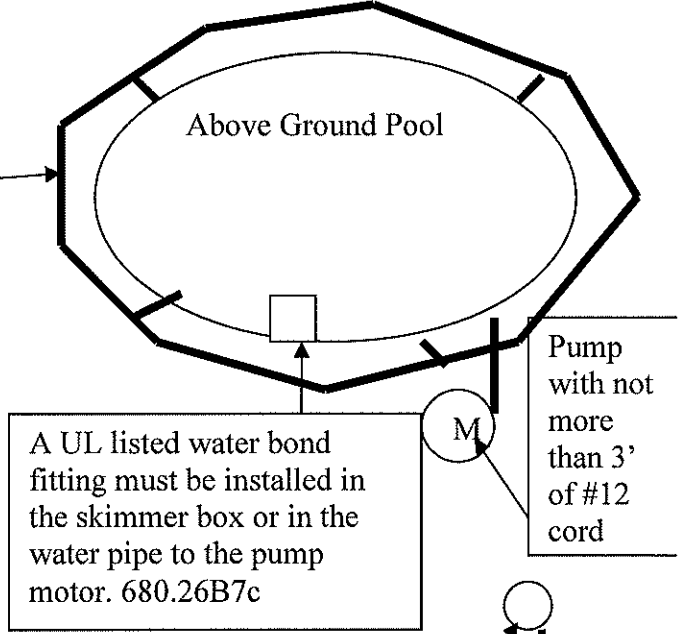

Single twist-lock pump receptacle located between 6' and 10' from pool. Art 680.22(2). A timer must be installed according to the '09' IECC 403.9.2.

General purpose GFI protected receptacle located between 6' and 20' from pool. Art.680.22(1) The receptacle must be a WR type, The words WR will be stamped on the face of the receptacle.

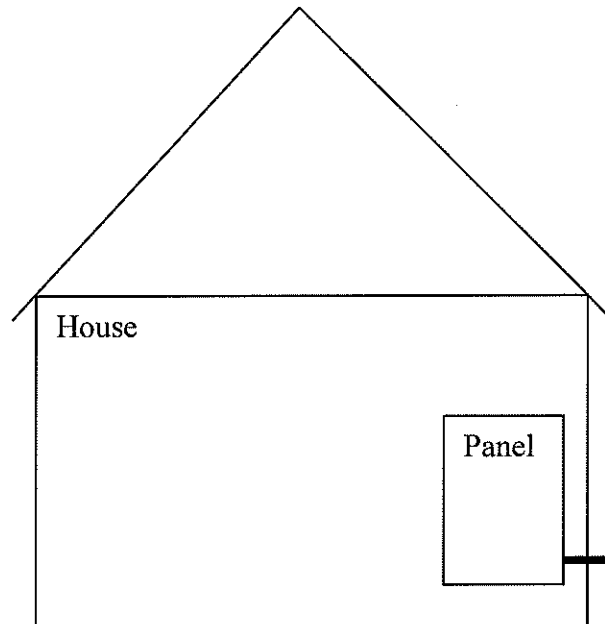

3/4" electrical PVC conduit and fittings. The burial depth is a minimum of 18". Conductors must be black, white and green, minimum #12 Type THWN copper on a dedicated 20amp circuit.